



ASSEMBLY HARDWARE



G*GRASS®

ASSEMBLY HARDWARE

Installation and assembly hardware for professional efficiency





Installation and assembly aids for all product families -
designed to suit our customer's needs.

Whether you want to insert a hinge or assemble
a drawer - Grass machinery offers the most
economical solution.

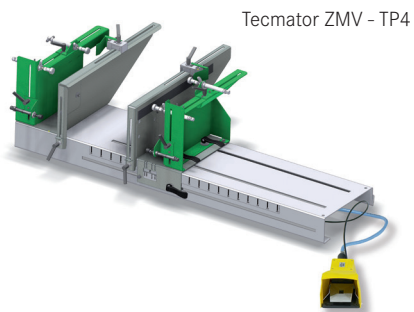

Tecmator ZMV - TP4

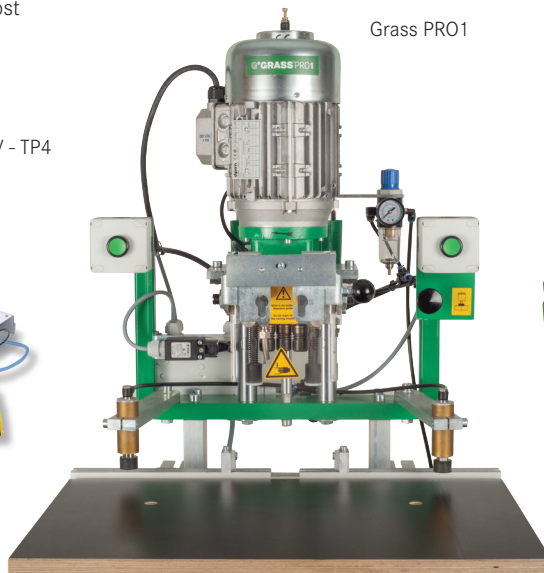









Grass PRO1

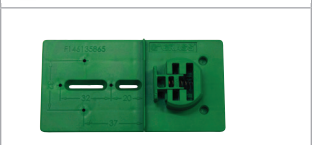

Grass ZRam

Table of Content

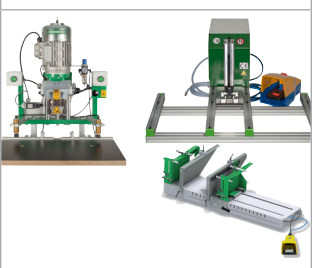
	Description	Page
	<p>UniSoft</p> <ul style="list-style-type: none"> • For all face frame overlay cabinets • For full overlay frameless cabinets 	4
	<p>Tipmatic</p> <ul style="list-style-type: none"> • For use with free swinging hinges • For handle free doors 	5
	<p>Soft-close Damper</p> <ul style="list-style-type: none"> • For Zargen Slides • Easy to mount 	6
	<p>Sensomatic</p> <ul style="list-style-type: none"> • For Vionaro, Dynapro, and Nova Pro Scala • Automatic drawer opening 	7
	<p>Cabinet Suspension</p> <ul style="list-style-type: none"> • Self-centering suspension rail • All steel material • Carrying capacity - 286 lb 	8
	<p>Accessories & Assembly Aids</p> <ul style="list-style-type: none"> • For TEC • For Tiomos • For Lifters 	9
	<p>Accessories</p> <ul style="list-style-type: none"> • Drawers 	10
	<p>Assembly Aids</p> <ul style="list-style-type: none"> • For Drawers • For Dynapro and Vionaro • For Nova Pro Scala 	12
	<p>Shelf Supports and Bumpers</p> <ul style="list-style-type: none"> • Supports made from steel and plastic • Various styles of plastic bumpers 	15
	<p>Screws and Dowels</p> <ul style="list-style-type: none"> • Euro and wood screws • Dowels for hinges and slides 	16
	<p>Machinery</p> <ul style="list-style-type: none"> • Grass PRO1 for 45mm boring • Grass PRO1 and ZRam for Zargen and ZBox • Grass PRO1 and Tecmator for Vionaro • Tecmator for Nova Pro Scala • ZVM for Nova Pro Scala and Vionaro 	17

Soft-close for doors



- Works for face frame cabinets on all door overlays
- Works for frameless cabinets on full overlay doors
- Brushed nickel look blends in well with hinge finish
- Non-handed with a low profile design
- Manually adjustable to desired closing speed
- Mounts independently from the hinge in the upper corner of the cabinet
- Instantly allows the cabinet door to close quietly and smoothly
- Scratch protector and front bumper with cushion for a quiet close

UniSoft Adapter

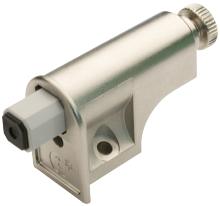

Description	Material	Item No.	PU
UniSoft, Polybag	Plastic, chrome	18971-37	1
UniSoft, Polybag Bulk	Plastic, chrome	18971-40	25
UniSoft, Bulk	Plastic, chrome	18971-14	250

Includes #6 x 3/4 Pan head screw

Installation Mounting Position Adjustment

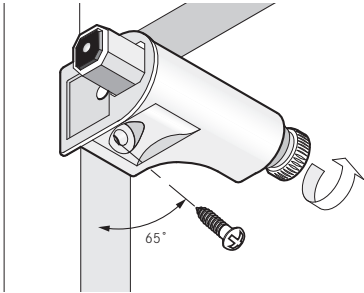

Use a 65° angle for best base results. Pilot drill 2.3mm (Ø3/32") and 1/4" deep for a #6 x 3/4" Pan head screw recommended. Mount in upper corner on hinge side.

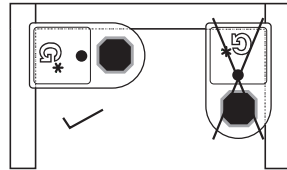

IMPORTANT The installation of our cabinetry hardware must comply with the Grass instructions that are stated on this catalog page.

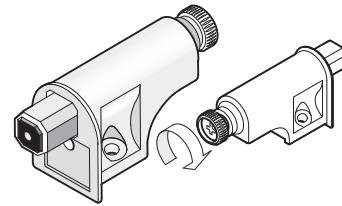

Turn adjustment screw to move damper in and out. Adjust in for heavier doors or out for light doors. Use Phillips or Pozidrive screwdriver or adjust manually.

Dimensions UniSoft per Door

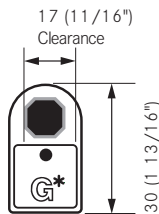
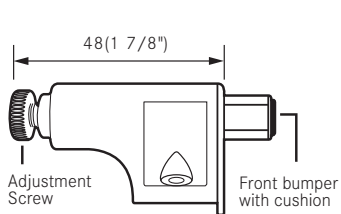

Use one UniSoft for most applications. For heavier doors use two or more. Trial mount recommended.

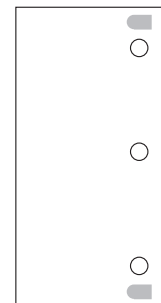
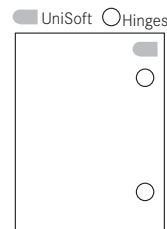

PU - Packaging unit

For handle-free wooden doors



- Gently tapping the front causes the doors to open to a convenient angle
- Use with Tiomos Tipmatic Plus or with Nexis and Tiomos free-swinging hinges
- Large magnet catch range – holds door closed securely
- Gap adjustment from 2.5 to 5.5mm with integrated, self-locking and tool-free depth adjustment feature
- Mount on the front side of the cabinet or with an adapter plate

Tipmatic Pin



- Incl. Tipmatic mechanism:
 - Stick on strike plate
 - Screw on strike plate
- Hole drilled from the front
- Plastic RAL 7036, platinum grey

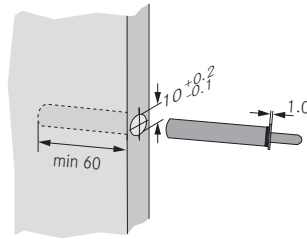

For Drilling

Item No.	PU
F069135396513	25

Adapter Plate for Line Boring



- Suitable for line boring 28 and 37mm
- Attach with Euro screws (6.3 x 13.5)
- Plastic RAL 7035, light grey

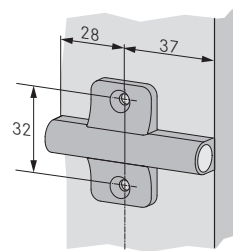

For Euro Screws

Item No.	PU
F069063310213	25

Face Frame or Standard Adapter Plate



- Quick upgrade installation
- Attach with wood screws (3.5 x 13)
- Plastic RAL 7035, light grey

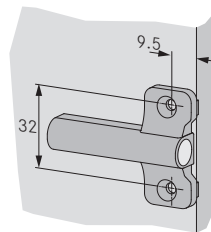

For Wood Screws

Item No.	PU
F069073697213	25

Linear Adapter Plate



- Design solution – also suitable for inset door applications
- Attach with wood screws (3.5 x 13)
- Plastic RAL 7035, light grey

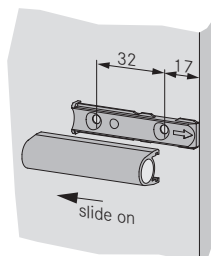

For Wood Screws

Item No.	PU
F069073696213	25

Soft-close Damper Set

Zargen

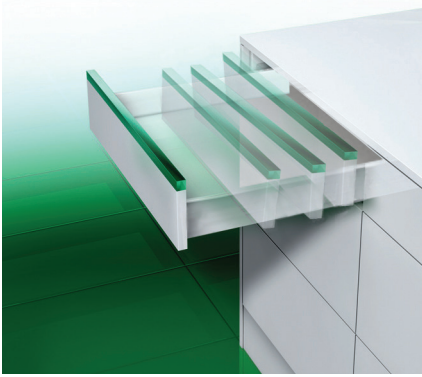

- Add-on damper creates a smooth soft-close action
- Liquid closing mechanism for improved performance
- Three options for various load capacities
- Actuator design allows for flush mounting
- Set includes: damper and actuator unit

Soft-close Damper

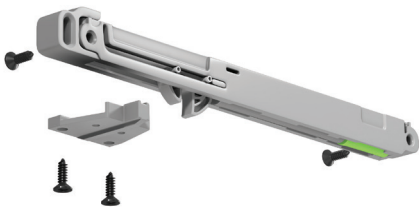

Description	Load Capacity	Item No.	PU
15 kg Damper set	33 lb	02564-11	140
30 kg Damper set	66 lb	02572-11	140
70 kg Damper set	154 lb	02565-11	140

Note: Damper sets do not include screws.

Zargen with Soft-close

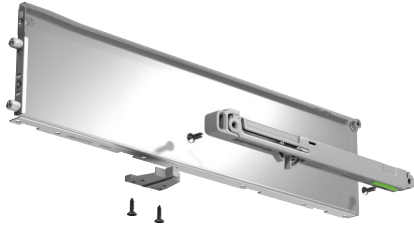

Note: Damper set does not include drawer components

For complete installation details, please see Zargen/ZBox catalog, pages 32-33

Dampers per Drawer

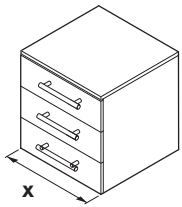

**33 lb (15 kg)
Damping Unit**

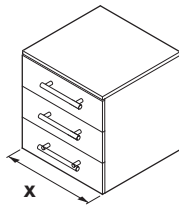
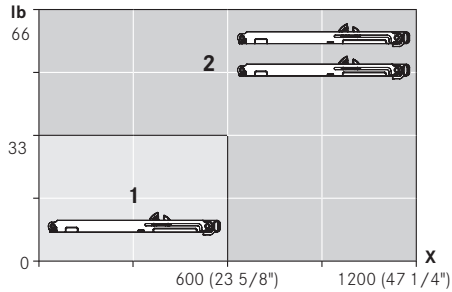

**66 lb (30 kg)
Damping Unit**

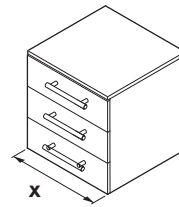
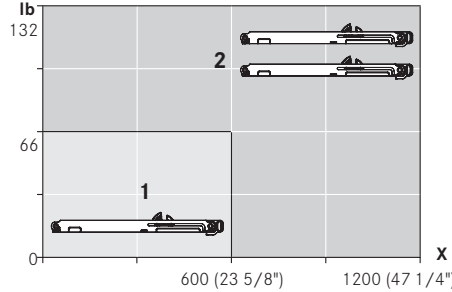

**154 lb (70 kg)
Damping Unit**

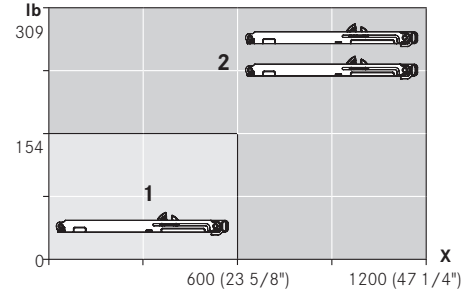

PU - Packaging unit

For Dynapro, Vionaro, and Nova Pro Scala

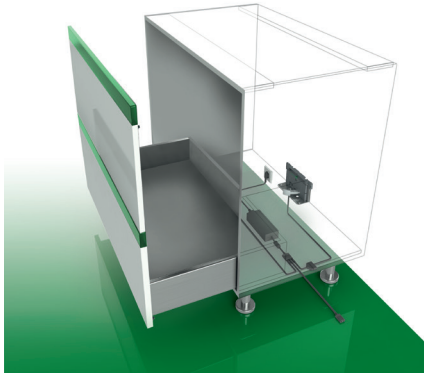

- Sensomatic works with any Dynapro, Vionaro, or Nova Pro Scala drawer system
- Activated by a light touch anywhere on the drawer front
- One drive unit for cabinet widths up to 47 1/4" (1200 mm)
- Full extension for maximum access to drawer contents
- Soft-closing action pulls the drawer closed

Sensomatic Kit



Set consists of:

- 1 - Opening unit
 - 1 - Base frame
 - 1 - Power supply unit
 - 1 - Power cord
 - 4 - Front Bumpers
- (F121100294223)**

Description	Item No.	PU
Sensomatic Kit	F121100697201	1

Note: For installation instructions see individual Online product catalogs

Cabinet Suspension

Suspension rail

Suspension Rail, Covers

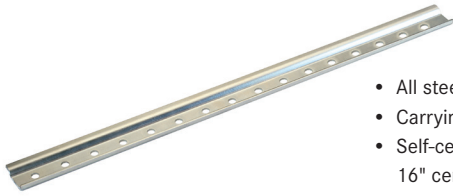

- All steel material
- Carrying capacity - 286 lb
- Self-centering suspension rail
16" center to center

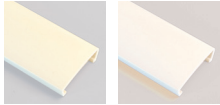

Almond

White

Description	Length	Material/Color	Item No.	PU
Rail	2438mm (96")	Steel	499.831.00.1719	25
Cover	2438mm (96")	Plastic, almond	499.831.00.0153	50
Cover	2438mm (96")	Plastic, white	499.831.00.0174	50

Suspension Rail Installation

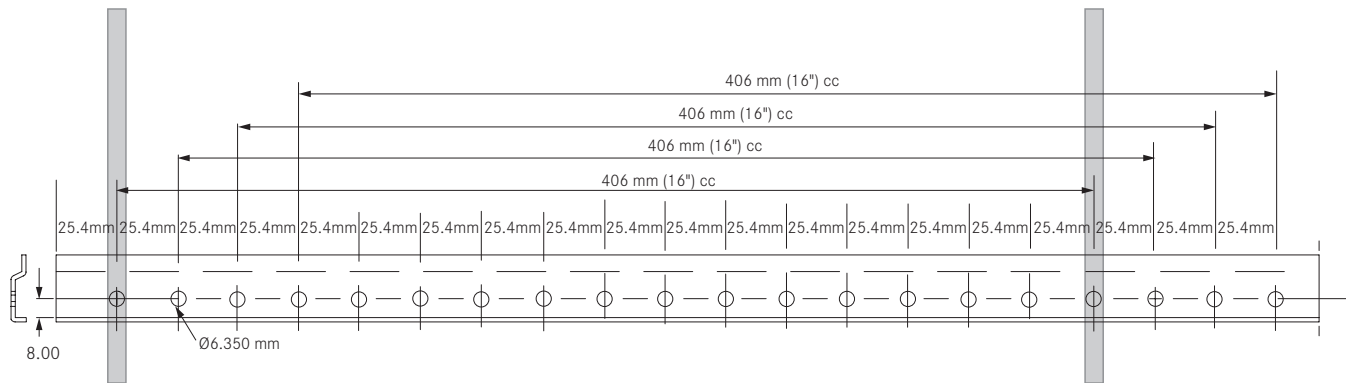

Assembly Screw



Description	Material/Color	Item No.	PU
6.3 x 16mm panhead screw	Steel	499.390.62.6115	5000

PU - Packaging unit

Accessories & Assembly Aids

Hinges and Lifters

Cover Caps



Hole covers for 35mm cup drillings

Description	Item No.	PU
35mm cover cap, white	22227-42	100

Timos Marking Jig

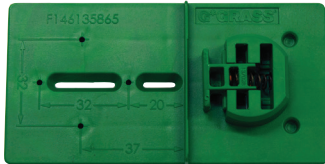

- Easy to use
- Cup distance 3-5mm
- Hinge cup positioning
- Straight base plate positioning
- Wing base plate positioning

Description	Item No.	PU
Timos marking jig	F146135865202	1

Timos Marking Template

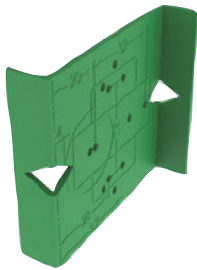

Easy marking and pre-drilling for:

- 45mm pattern hinges
- Wing base plates
- Straight base plates

Description	Item No.	PU
Timos marking template	F146135787217	1

Hand Insertion Tool for TEC



Description	Item No.	PU
TEC Hand insertion tool	03987-01	1

Kinvaro Installation Templates

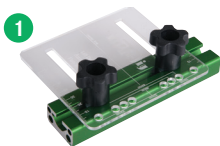

Drilling templates for the Kinvaro Lifter System. Each lifter has an individual template for easy installation. Order each drill jig with appropriate bit.

Example: Kinvaro F-20 order:

- 1** 1 - Kinvaro Door Template Drill Jig
- 2a** 1 - 5mm or 9/16" drill bit
- 2b** 1 - Kinvaro F-20 Drill Jig

Description	Item No.	PU
1 Kinvaro Door Template Drill Jig	00495-01	1
2a Kinvaro 5mm drill bit	00496-01	1
2b Kinvaro 9/64" drill bit	00497-01	1

Description	Item No.	PU
A Kinvaro L-80 Drill Jig	00490-01	1
B Kinvaro F-20 Drill Jig	00491-01	1
C Kinvaro T-65 Drill Jig	00492-01	1
D Kinvaro T-71/T-76 Drill Jig	00493-01	1
E Kinvaro T-57 Drill Jig	00494-01	1

PU - Packaging unit

Accessories

Drawers

Inset Bracket Set

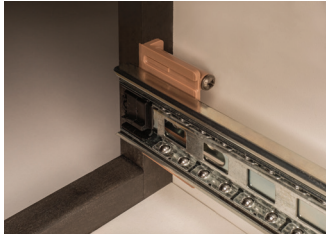

- For face frame inset applications
- Bracket mounts behind the face frame, minimum 12.7mm (1/2") frame offset required
- Slides attach easily with one screw
- Includes guide markings for proper setback



Polybag set consists of:

- 2 - Universal Inset Bracket ABS Brown
- 2 - 8 X 32 Tapped Insert for Inset bracket
- 4 - #7 X 2" Mounting Screws
- 2 - #8 - 32 X 1/2" Machine Screw FHP
- 1 - Instructions

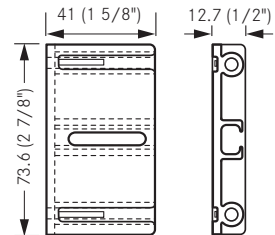

Description	Item No.	PU
Inset bracket set	13901-37	1
Inset bracket set	13901-08	50

Interior Drawer Bracket



- Used to mount slides to a cabinet bottom or shelf for interior roll out trays.
- Works with Dynapro, Elite Plus, and Nova Pro Scala drawer slides

Description	Item No.	PU
Interior drawer bracket, set	00443-40	25

Set consists of:

- 4 - non-handed, zinc plated, steel brackets
- 8 - M4 screws to attach slides to brackets
- 8 - #8 x 5/8" PHP screws to mount brackets to cabinet

Nova Pro Scala

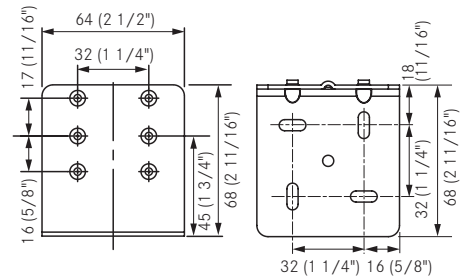
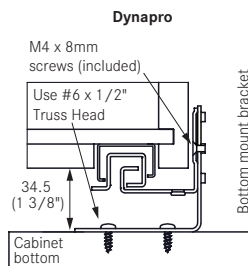
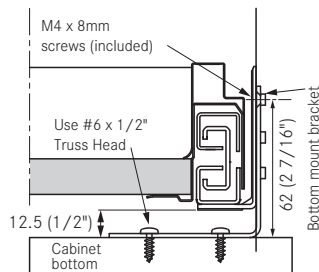
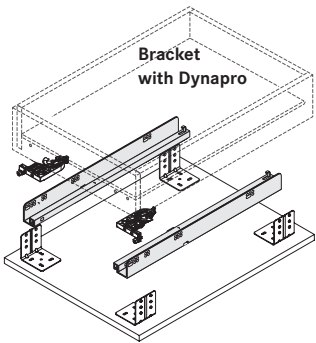

PU - Packaging unit

Accessories

Drawers

6195 Spacers for Cabinet Members



Designed to provide side clearance for interior drawers and pullout shelves.

Description	Item No.	PU
1 6195 Spacer, 25mm	F145086478111	20
2 6195 Spacer, 11mm	89104-39	20
3 6195 Spacer/pin, 25mm	13097-39	20

6195 Spacer, 25mm

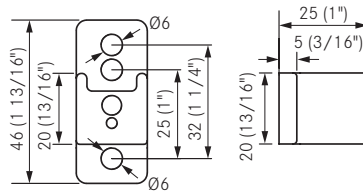

6195 Spacer, 11mm

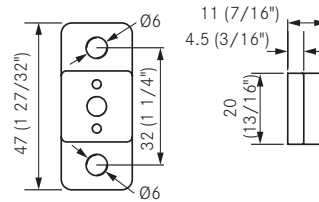

6195 Spacer/pin, 25mm

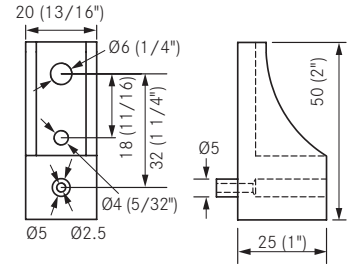

Door/Drawer Protector



Attaches to side of wooden pull-out. Designed for inset pull-out trays for face frame or frameless cabinetry.

Description	Item No.	PU
Door/drawer protector	13096-43	white 500

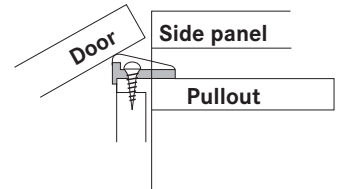

Drawer Front Adjuster



For precise drawer front alignment

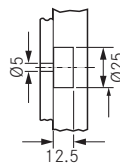

Description	Item No.	PU
Plastic, black	351.002.01.2662	200

Includes 4 x 22mm screw

Assembly Aids

Drawers

Drilling Template for Drawer Back



- Use to precisely bore holes in the drawer back
- Use with a standard 1/4" (6mm) drill bit and stop collar
- For use with Grass undermount slides.



Left Side Drilling

Right Side Drilling

Description	Item No.	PU
Drilling template	02511-01	1

Assembly Aids



The non-flanged FLD drilling jig is used for mounting non-flange front locking devices to the drawer box for Dynapro, Elite Plus, and Maxcess.

The GRASS centering drill bit is used for pre-drilling countersink wood screws, Ø 2.5mm.



Description	Item No.	PU
1 Non-flanged FLD Drilling Jig	00004	1
2 Centering drill bit	35692-01	1

Drill Bits for Aluminum Front Pull Outs



Description	Item No.	PU
Drill bit, 3mm, RH, for Vionaro	00156-01	1
Drill bit, 8mm, RH, for Vionaro	00158-01	1

Assembly Aids

Dynapro and Vionaro

Dynapro Assembly Aids

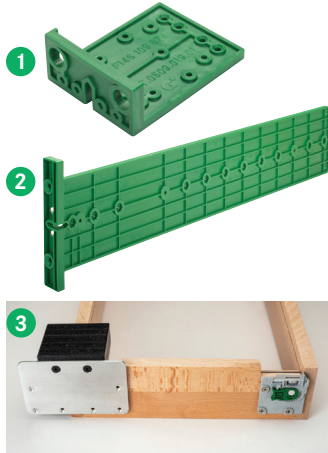

Drawer Drilling Template for drilling front locking devices, drawer hole hook, or adjustment adapters

The Dynapro rear tilt adapter jigs are designed for locating the position of the tilt adapter on the drawer box back. The jigs are available for 16mm and 19mm drawer material.

Description	Item No.	PU
1 Drilling template - Drawer	F146109874299	1
2 Drilling template - Cabinet member	F146101348507	1
3 Dynapro Rear Tilt Adapter Drilling Jig 16mm	00005	1
Dynapro Rear Tilt Adapter Drilling Jig 19mm	00006	1

Drilling Jig



Front drilling jig for Vionaro front adapter

Description	Item No.	PU
Drilling jig	F146100562201	1

Marking Jig

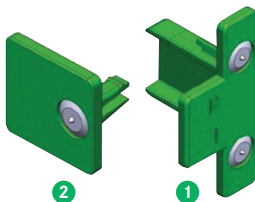

For exact marking of the drilled holes for the Vionaro front adapter

Set contains:

- 1 1 - marking jig for front connector
- 2 1 - marking jig for front stabilizer

Description	Item No.	PU
Marking jig	F146100545513	1

Punching Tool for Vionaro Front Stabilizer



Description	Item No.	PU
Front stabilizer punching tool	F146116216299	1

Front Adapter Tool for Vionaro

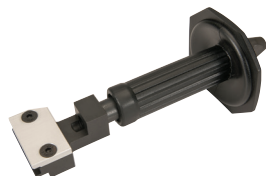

Description	Item No.	PU
Vionaro front adapter tool	F146116213299	1

Punching Tool for Vionaro Bottom Spike



Description	Item No.	PU
Bottom spike punching tool	F146116217299	1

Assembly Aids

Nova Pro Scala

Marking Jig Set



For exact marking of the drill holes for the Nova Pro Scala front brackets.

Description	Item No.	PU
Nova Pro Scala H63	F146094036513	1
Nova Pro Scala H90	F146092050513	1
Nova Pro Scala H186/H250	F146101908513	1

Front Drilling Jig



Front drilling jig for Nova Pro Scala front fastening, railing and add-on systems:

- Can be used for drilling drawer sides of all heights
- High-quality aluminum construction

Description	Item No.	PU
Front Drilling Jig	F146130983201	1

Punch-In Tool for Front Brackets



Position and install the front brackets for the Nova Pro Scala H63, H90, and H186.

Description	Item No.	PU
Nova Pro Scala H63	F146094035501	1
Nova Pro Scala H90/H186	F146091555501	1

Punch-In Tool for Front Clip



Position and install the front clip for Nova Pro Scala H186.

Description	Item No.	PU
Punch-in tool for front clip	F146102472101	1

Punch-In Tool for Front-Bottom Connector



Position and install the front-bottom connector.

Description	Item No.	PU
Punch-in tool for front-bottom connector	F146083271101	1

PU - Packaging unit

Shelf Supports



Description	Item No.	PU
Shelf support 7006/9.5, nickel	F069073460 253	2500
H-802 plastic, square, clear	00036-43	500

Bumper Pads

Bumper Pads, Self-adhesive



Description	Height	Diameter	Item No.	PU
Bumper pad, clear	2.5mm	10mm	63407-99	288
Bumper pad, clear	2.5mm	10mm	63407-47	7200

AirSoft Bumper Pads, Self-adhesive



Description	Height	Diameter	Item No.	PU
AirSoft Bumper pad, clear	5mm	12.7mm	63481-43	500
AirSoft Bumper pad, clear	5mm	12.7mm	63483-30	5000

Bumper Pads, Self-adhesive



Description	Height	Diameter	Item No.	PU
Bumper pad, clear	1.5mm	7mm	630.000.03.0750	1088
Bumper pad, clear	4mm	12mm	630.000.02.1250	5000

Bumper Pads, Self-adhesive



Description	Height	Diameter	Item No.	PU
Bumper pad, clear	3mm	12.7mm	31002-43	500
Bumper pad, clear	1.5mm	12.7mm	31004-43	500

Door Stop



Description	Item No.	PU
H-950 door stop, clear	00068-43	500

Assembly Hardware

Screws and Dowels

Euro Screw, Nickel-plated



Description	Item No.	PU
1 13mm Euro Screw (1/2")	81015-43	500
18mm Euro Screw (11/16")	83000-43	500
7.5mm Euro Screw (5/16")	83001-43	500
2 Euro Screw 11mm (7/16") Pozi	499.360.61.1015	500
Euro Screw 13mm (1/2") Pozi	499.360.61.3015	500

Wood Screw, Nickel-plated

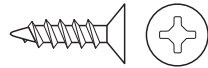

Description	Item No.	PU
#6 x 1/2" FHP, NI	81014-43	500
#6 x 5/8" FHP, NI	81001-43	500
#6 x 3/4" FHP, NI	81003-43	500
#6 x 1" FHP, NI	81004-43	500

Wood Screw, Nickel-plated

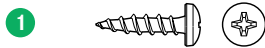

Description	Item No.	PU
1 #10 x 3/4" PHP	81007-43	500
2 #8 x 5/8" Quad Round	81017-43	500

Dowels, Plastic

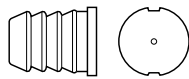

Description		Item No.	PU
Dowel, TEC Hinge	8mm	00102-43	500
Spax screw for TEC Hinge Dowel		02445-43	500
Dowel, Nexis	8mm	F069073390256	500
Dowel, Tiomos	8mm	F072135773247	1000
Dowel, VZ Hinge Cup	8mm	04885-43	500
Dowel, Zargen / ZBox	10mm	05853-42	100
Dowel and screw set Zargen	10mm	12768-37	1
Dowel, base plate	10mm	05404-43	500
Dowel, pilaster dowel	8mm x 16mm	00395-43	500

Pozidrive Screwdriver

#2 Pozidrive screwdriver for hinges



Description	Item No.	PU
Pozidrive screwdriver	98000-01	1
Pozidrive screwdriver	98000-08	50

PU - Packaging unit

Grass PRO1 drilling and insertion machine for 45mm boring pattern

Grass PRO1 for Hinge Drilling



- Depth stop can be adjusted to material thickness
- Functional design
- Easy, fast and efficient operation
- Easy maintenance
- 45mm boring pattern

Description	Item No.	PU
220v single phase pneumatic	94559-01	1
220v three phase pneumatic	94560-01	1
110v single phase pneumatic	94561-01	1



Description	Item No.	PU
Extension fence 300mm to 1550mm	88612-01	1

Drill Bits

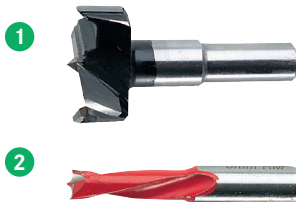

Description	Direction	Item No.	PU
1 35mm bit	RH	00077-01	1
2 8mm bit	LH	00160-01	1
American Bit Set for Hinge Drilling		00213-01	1

Set consists of:

- 1 - 35mm bit, RH
- 2 - 8mm bit, LH

Fence Stops

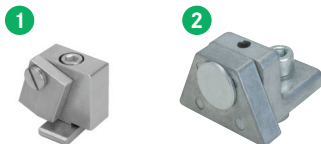

Description	Item No.	PU
1 Additional fence stop	949.200.21.0000	1
2 Additional fence stop, large	949.200.21.0100	1

Insertion Dies

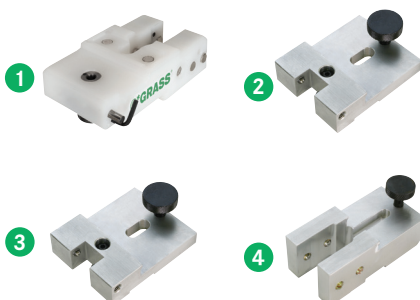

Description	Item No.	PU
1 Tiomos Universal Insertion Die 110°/120°/160°	80039	1
2 TEC Insertion Die	92617	1
3 Nexis Insertion Die 110°/125°	04216-01	1
4 Nexis Insertion Die 170°	04218-01	1

PU - Packaging unit

Machinery

Grass PRO1 and ZRam for ZBox and Zargen Assembly

Grass PRO1 for ZBox and Zargen



- Depth stop can be adjusted to material thickness
- Functional design
- Easy, fast and efficient operation
- Easy maintenance
- 3 spindle gear box

Description	Item No.	PU
220v single phase pneumatic	80131	1
220v three phase pneumatic	80132	1
110v single phase pneumatic	80068	1

Note: Machine Item Numbers above include the three items in PRO1 Kit #80154

ZBox and Zargen Conversion Kit

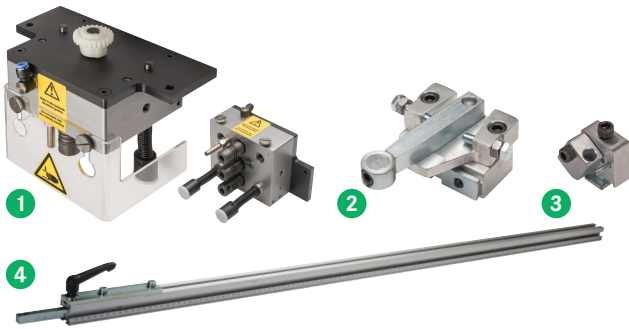

Description	Item No.	PU
1 PRO1 Gear box	80151	1
2 PRO1 Side-to-side Stop	80153	1
3 PRO1 13mm Fence Stop	80152	1
PRO1 Kit (gear box, fence and side stops)	80154	1
4 Extension fence 300mm to 1550mm	88612-01	1

Bits

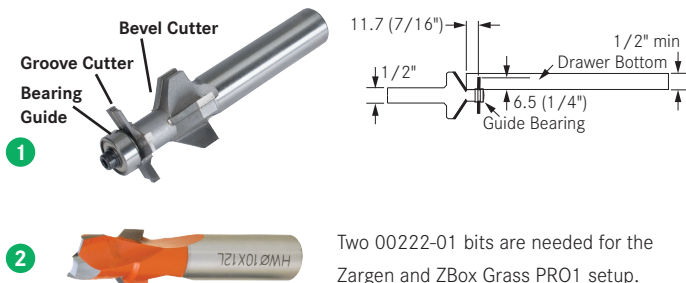

This bit is designed for grooving and beveling the drawer bottoms for the lipped version of the ZBox and Zargen drawer slide. The bit comes only with a 1/2" shank.

Description	Item No.	PU
1 Router bit	00197-01	1

Description	Item No.	PU
2 10mm Carbide counter sink drill bit, LH	00222-01	1

Two 00222-01 bits are needed for the Zargen and ZBox Grass PRO1 setup.

ZRam



- Designed for semi-automated assembly of ZBox and Zargen slides
- Operated by a foot pedal – air required
- No adjustment required when using various heights or when switching slide types
- Economical solution for drawer assembly

Description	Item No.	PU
ZRam	93250-01	1
ZRam Retrofit Kit	69401	1

PU - Packaging unit

Machinery & Assembly Aids

Grass PRO1 and Tecmator for Vionaro

Grass PRO1 for Vionaro



- Depth stop can be adjusted to material thickness
- Functional design
- Easy, fast and efficient operation
- Easy maintenance
- 3 spindle gear box

Description	Item No.	PU
220v single phase pneumatic	80063	1
220v three phase pneumatic	80064	1
110v single phase pneumatic	80065	1



Description	Item No.	PU
Extension fence 300mm to 1550mm	88612-01	1

Drill Bits

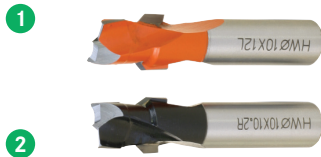

Description	Direction	Item No.	PU
1 10mm Carbide counter sink bit	LH	00222-01	1
2 10mm Carbide counter sink bit	RH	00229-01	1

Insertion Die



Description	Item No.	PU
Vionaro insertion die	30683-01	1

Tecmator ZMV - TP4

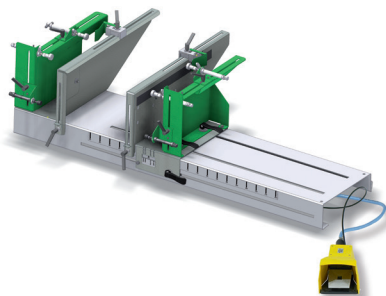

- Pneumatic table-top device for Vionaro
- The ZMV-TP can be used to assemble drawers for external cabinet widths of up to 1200mm
- Easy and straightforward handling
- Sturdy construction
- For small series production
- Pneumatic control system
- High performance

Description	Item No.	PU
Tecmator ZMV-TP4	F146108668201	1

Note: Product lead time approximately 14 weeks

PU - Packaging unit

Machinery

Tecmator for Nova Pro Scala

Tecmator ZP-N-E2

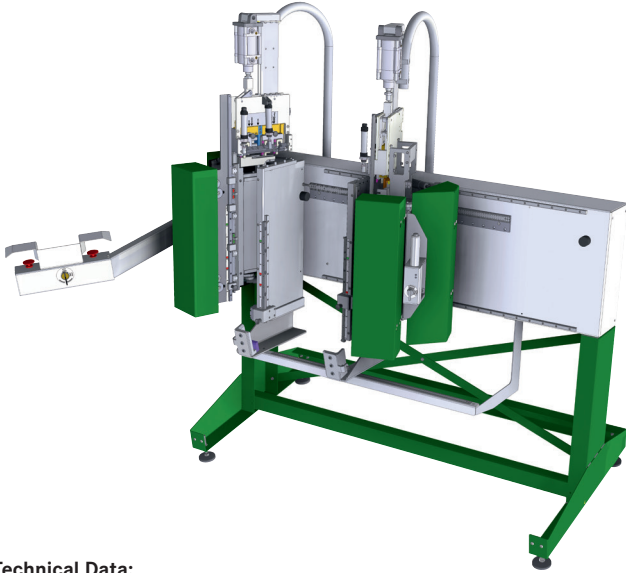

Technical Data:

- Pneumatic Connections: min 6 bar to max 10 bar
- Dimensions: 2.45m W x 1.0m D x 2.2m H (96 7/16" W x 39 3/8" D x 86 5/8" H)
- Weight: 220 kg (485 lbs)

Machine Application:

- Suitable for assembling Nova Pro Scala drawers – without having to change the press-in brackets
- Suitable for assembling wooden back panels
- Can be used to assemble wooden back panels with Nova Pro Scala H250 (3 dowels)
- For drawer widths up to 1200mm

Features:

- Nova Pro Scala drawers can be assembled in 10 seconds
- Easy handling of parts on the machine
- Sturdy frame construction
- Flexible adjustment of the drawer width using the wooden back panel template (as standard or can also be retrofitted)
- The width is easily adjustable using pneumatic clamping
- Fast operating sequences

Standard equipment:

- Bottom claw pressing for all nominal lengths
- Stop set for cabinet width 250 – 1200 (50 mm increments)
- Stops for wooden back panel heights

Description	Item No.	PU
Tecmator ZP-N-E2, type 1.2 m	F146131003299	1

Note: Product lead time approximately 14 weeks

Tecmator Features

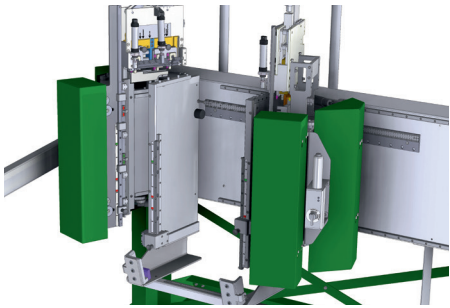

Easy width adjustment due to pneumatic clamping

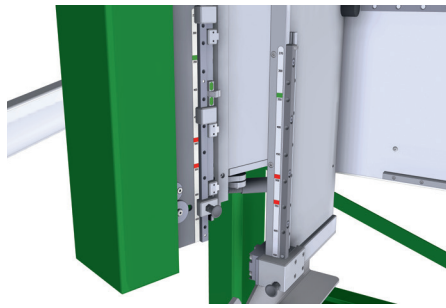

The individual components of the machine can be easily handled

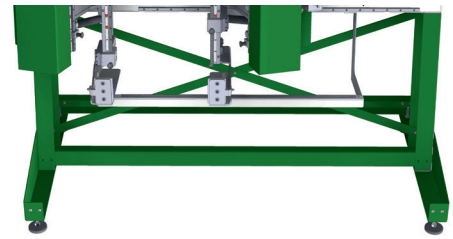

The frame structure ensures excellent stability

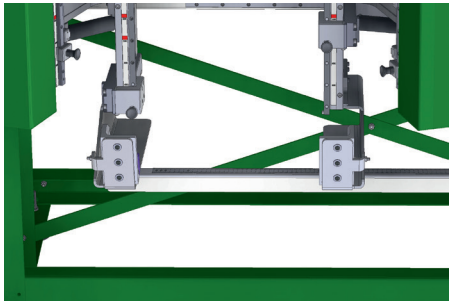

Customized cabinet width settings possible via the wooden back panel

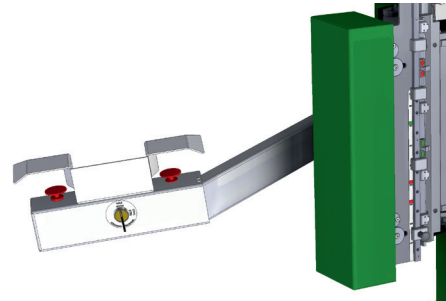

Maximum safety based on two-handed switching

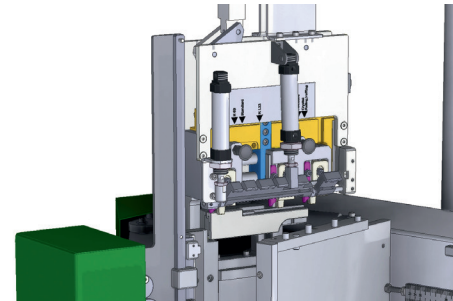

Press aggregate for wooden back panels up to 250mm with up to 3 dowels per side

PU - Packaging unit

Machinery

Tecmator for Nova Pro Scala H186

Tecmator ZP-N-Wood H186

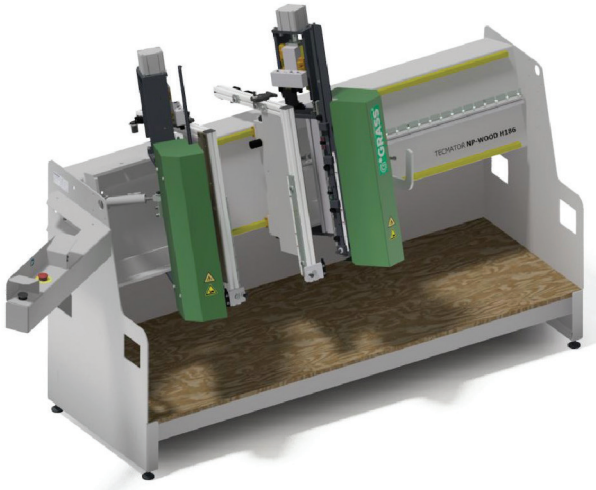

Machine Application:

- For Nova Pro Scala drawers with wooden backs
- Assembles side heights up to 186mm
- For cabinet widths 250mm - 1200mm

Features:

- Easy and fast drawer assembly
- Easy handling of parts on the machine
- Sturdy frame construction
- Suitable for rapid production
- Flexible setting of the drawer width with a wooden back panel gauge
- Easy width adjustment

Standard equipment:

- Bottom claw pressing for all nominal lengths
- Stop set for cabinet width 250 - 1200 (50 mm increments)
- Stops for the wooden back panel depth

Technical Data:

- Pneumatic Connections: min 6 bar to max 8 bar
- Dimensions: 2.65m W x .92m D x 2.3m H
(104 5/16" W x 36 1/4" D x 90 9/16" H)
- Weight: 249 kg (549 lbs)

Description	Item No.	PU
Tecmator ZP-N-Wood H186	F146032089299	1

Note: Product lead time approximately 14 weeks

Tecmator Features

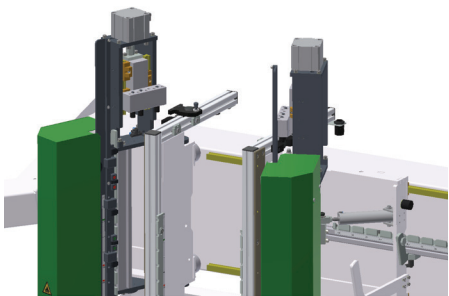

Simple width adjustment with defined grid and flexible clamping lever

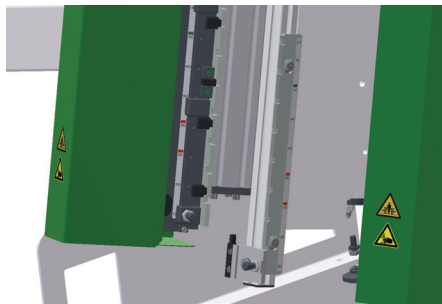

Machine stops can be easily set

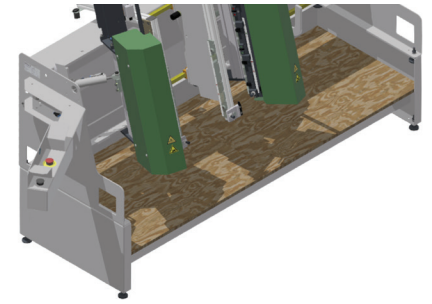

The frame structure ensures excellent stability

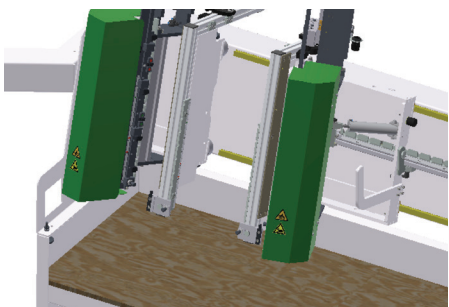

Customized cabinet width settings possible via the wooden back panel

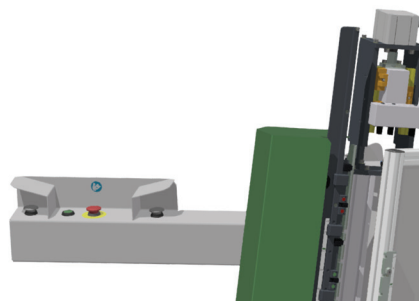

Maximum safety based on two-handed switching



Dowel press fitting for wooden back panels up to side height 186mm

PU - Packaging unit

Machinery

For Nova Pro Scala and Vionaro

ZMV-FIX H250

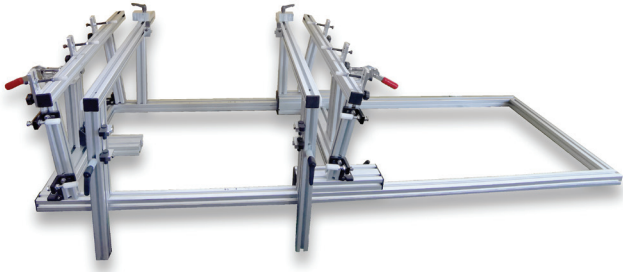

Machine Application:

- Tabletop drawer press suitable for pressing Grass double wall drawer systems including Nova Pro Scala and Vionaro.
- For drawers with wooden back panels
- Drawer side heights of up to 250mm
- Variable drawer width up to 1200mm

Features:

- Easy and straightforward handling of the individual parts on the machine
- Light frame construction 12 kg (26.5 lb)
- Suitable for individual production
- Flexible setting of the drawer width with a wooden back panel gauge (standard)
- Easy width adjustment

Standard equipment:

- Flexible setting of the stops for the drawer depth
- Flexible setting of the stops for the wooden back panel heights
- Flexible setting of the drawer width with a wooden back panel gauge

Description	Item No.	PU
ZMV-FIX H250	F146132388201	1

Insertion Die for Dowelled Front Brackets



- For use with Nova Pro Scala Front Brackets
- Works with Grass Ecopress machine

Description	Item No.	PU
Insertion Die for dowelled front brackets	94488-01	1

PU - Packaging unit



GRASS America Inc.
1202 NC Highway 66 South
Kernersville, NC 27284

Phone: 1-800-334-3512
Fax: 1-800-525-8406

www.grassusa.com
info@grassusa.com

